



# AIRBRASIVE® UNIT MODEL 6500 SERIES II AU601

Service Manual  
Operation & Maintenance Instructions with Illustrated Parts List

Airbrasive Jet Technologies, LLC  
200 School Alley Suite 7  
Green Lane, PA 18054

Email: [info@airbrasive.com](mailto:info@airbrasive.com)  
Phone: (866) 272-0540

[www.airbrasive.com](http://www.airbrasive.com)

Revised: December 2022

# Overview

## AIRBRASIVE® MICRO ABRASIVE BLASTING TECHNOLOGY

Airbrasive® Jet Machining is a process in which high pressure air and very fine powder are blended in a chamber to form an abrasive mixture. This mixture is then sent through a small, precisely machined nozzle. The result is a highly accurate abrasive stream that can be used for cleaning, cutting, drilling, deburring, and finishing all types of surfaces. Airbrasive® Machines have limitless applications. These highly engineered machines are incredibly versatile. They have the power to cut and drill materials as hard as diamonds, as well as the precision to delicately clean debris from ancient papyrus documents.

## OPERATING PRINCIPLES

The Airbrasive® Machine is capable of many cutting and abrading tasks. From cutting very hard materials such as diamonds to cleaning extremely delicate items like fabric or paper. The key to taking advantage of its versatility is the knowledge of how it cuts. Knowing this, you can properly set the various controls to achieve your desired cutting results. There are six key variables involved in the cutting process. 1) Air Pressure, 2) Powder Flow Rate, 3) Nozzle Size, 4) Type of Powder, 5) Nozzle Distance from work piece, and 6) Angle of Impingement.

## AIR PRESSURE

The air pressure is directly related to the velocity of the powder particles striking your work piece. The higher the air pressure the faster the particles and the greater the cutting speed. The lower the pressure the, lower the cutting speed. This is not a linear correlation. There are certain critical points you will notice as you experiment with different air pressure settings. When the particle velocity falls below a certain level the cutting action may suddenly stop altogether. Similarly, a small increase in air pressure may gain a large increase in cutting action. The air pressure is limited at the high end by safety concerns and by what your main air supply can produce.

**The unit should never be pressurized beyond 140 PSI!**

## POWDER FLOW RATE

The amount of powder exiting the nozzle per minute is referred to as the flow rate. The greater the flow rate, the greater the cutting action. To achieve the better cutting action with higher powder flow rates, it is often necessary to increase the air pressure. This is done to maintain particle velocity which tends to slow down as the mass the air stream must carry increases. Cutting action will decrease quickly at very high powder flow rates. This is due to interference between the powder particles bouncing off the work piece and those coming out of the nozzle. Some brief experimentation at these high flow rates will quickly reveal your limits.

## NOZZLE SIZE

Nozzle orifices are shaped to be either round or rectangular. The nozzle widths vary in size from .005 up to .032 inches. The size of the nozzle determines the area that will be impacted by the powder. The larger the nozzle, the greater the area. The shape of the nozzle is important for getting into unusually shaped spaces. A rectangular nozzle can lightly cover a large width or, when turned, heavily impact a narrow space.

## TYPE OF POWDER

The cutting powder is the most important variable in the "Airbrasive" process. It determines the severity with which you will impact your part. Some powders are designed for aggressive removal of material while others for a gentle cleaning. To achieve consistent, sputter free smooth flow it is necessary to use uniformly sized powder. If the powder particles vary in size, even a little, the powder will tend to clump together. This happens because the smaller particles fill in the gaps between the larger particles, effectively locking them all together. If all the particles are of the same size, then this locking action cannot take place.

## NOZZLE DISTANCE TO WORKPIECE

The distance you hold the nozzle from the work piece plays a large part in determining the area covered as well as the cutting rate.

## ANGLE OF IMPINGEMENT

The angle at which you hold the nozzle regulates the speed and efficiency by which material can be removed from the work piece. There are two theories at play here, one based on material removal by brittle failure and the other on material removal by ductile failure. Brittle failure occurs when impacting powder granules penetrate the work surface and literally blast particles out of it. Ductile failure occurs when the powder granule strikes the work surface at an angle of less than 90 degrees and removes material by generating a chip.

Tests have shown that maximum material removal for ductile materials occurs between a 15- and 45-degree angle of incidence. For a brittle material, maximum removal occurs at an angle of 90 degrees.

# Section 1: Introduction and Description

## INTRODUCTION

- A. Scope. This technical manual contains operation and service instructions, as well as an illustrated parts list for the Airbrasive® Model 6500 Series II manufactured by Airbrasive Jet Technologies, LLC.
- B. Characteristics. This Unit is an Airbrasive Jet Machining System. This device will cut, drill, clean, etch, and deburr materials. Finely graded abrasive particles are propelled at high velocity through precision nozzles to strike the work area. The 6500 does not need electricity to run. The powder flow is caused by vibration generated by a "pneumatic vibrator" using compressed air. The 6500 is also equipped with a quick powder change feature. The Unit is designed specifically to use a variety of nozzles and specially prepared Airbrasive powders produced and distributed by Airbrasive Jet Technologies.

## SPECIFICATIONS

1. Air Supply Requirements	95 ± 45 PSI (50 PSI min., 140 PSI max.)
2. Electrical Power Requirements	None
3. Weight	18 lbs. (8.2 kg)
4. Dimensions	13" x 9-5/8" x 7-1/2" (H x W x D) 33 cm x 24.5 cm x 19 cm (H x W x D)

**WARNING:** The use of oxygen as a gas supply presents the possibility of an explosion occurring. Under no circumstances should oxygen be used.

**IMPORTANT:** A suitable dust collector system is required to maintain operator's exposures to powder dusts below permissible exposure limits such as those regulated by OSHA or recommended annually by ACGIH (American Conference of Governmental Industrial Hygienist). Consult the manufacturer of the dust collector equipment for the correct filter for other dusts or air contaminants resulting from material being abraded.

## AIR SUPPLY NOTE

Many compressed air lines are contaminated with moisture, oil, and dirt, which are detrimental to the performance and operation of the Unit. Moisture filters and unloaders must be used. These items can be purchased directly from Airbrasive Jet Technologies, LLC.

## POWDER NOTE

The MODEL 6500 UNIT is designed to use specially prepared powders that are meticulously screened for uniform particle size. These specialty powders insure smooth flow through the many precision ports and feedthroughs. The use of any other type of powder can result in clogging of the internal components and potential damage to the unit. For more information on these powders, contact Airbrasive Jet Technologies, LLC at (866) 272-0540.

## DESCRIPTION

The front panel of the unit includes an on/off switch, "on" indicator, air pressure regulator, pressure gage, powder flow control, handpiece, and an on/off foot switch. The black tubing extending from the rear of the machine is for an output from an external air supply. The components of the unit provide a controlled mixture of powder in a dry air stream and delivers this mixture to a tungsten carbide nozzle tip in the handpiece.

## AIRBRASIVE® MODEL 6500: STANDARD EQUIPMENT

Description	Part #	Qty	Description	Part #	Qty
Airbrasive® Model 6500	AU601	1	Nozzle (Straight, Round, .018" I.D.)	AN119	1
Nozzle & Handpiece Assembly	AH101X	1	Nozzle (Straight, Rectangular, .006" x.060")	AN124	1
Foot Switch	AR105	1	AccuBRADE 27-Aluminum Oxide	AP101	1
Nozzle (Straight, Round, .032" I.D.)	AN106	1	AccuBRADE 50-Aluminum Oxide	AP105	1

## Section 2: Preparation for Use

### INITIAL PROCEDURE

- A. **Unpacking:** The Unit and all accessory equipment are shipped in a single container. As the unit is unpacked, check all the items against the list of contents packed and with the items listed in Table 1-2. Do not discard any packing material until all deliverable items have been checked against the list of contents.

NOTE: Refer to the illustrations and parts lists in Section 6 as required to identify parts and components called out in these procedures.

### SUPPLY REQUIREMENTS

- A. **Air Supply Requirements:** Minimum - 40 PSIG (2.7 bar). Maximum - 140 PSIG (9.5 bar). To utilize the Unit to maximum advantage, an air supply pressure of 85 PSIG (5.8 bar) should be available. Cutting and cleaning rates increase as the pressure of the Micro-Blast nozzle is increased. This pressure can be adjusted with the panel-mounted control from 10 PSIG (0.7 bar) up to the limit of the air supply. The air supply must be clean and dry! The Airbrasive Air/Oil filter (part number AA111) will satisfy this requirement.

NOTE: Operating your Micro-Blast 6500 System over 85 PSIG can cause excessive wear of parts, increasing replacement rates.

- B. **Dust Collection:** A dust collector is required to keep operator exposure to dusts below the permissible exposure limits regulated by OSHA (Occupational Safety and Health Association) and ACGIH (American Conference of Government Industrial Hygienists). Airbrasive Jet Technologies has a dust collecting system available. Consult Airbrasive for the correct type of dust collection system to suit your needs.

### INSTALLATION

The work chamber and the Unit should be situated either next to each other or with the Unit on top of the work chamber.

**IMPORTANT:** Follow these instructions every time you need to open the front panel.

- A. **Filling the Powder Chamber:** Observe the following procedures when filling the powder chamber of the unit:
- Place the POWER switch of the unit to the OFF position.
  - Open the door of the powder section by pulling the top of the door toward you and down until it stops. This action exposes the powder chamber and quick release clamp.
  - Grasp the powder chamber in one hand and open the clamp by pulling the handle toward you with the other hand.
  - Loosen clamp and remove the powder chamber.
  - Fill the powder chamber with the desired amount of powder.

**WARNING: DO NOT OVERFILL**

NOTE: Make certain that no lint, dirt, or other foreign substances enter the mixing chamber. They can clog the mixing chamber orifice plate.

- Clean the sealing surface of the Powder Chamber.
  - Return the chamber to the unit. Make sure the chamber is correctly seated. If clamp is difficult to close, open it and re-seat chamber. Secure the clamp and close the door completely.
- B. **Air Filter Connection**
- The air supply hose (1/4" [6.4mm] diameter X 10' [3m]) enters into the rear of the unit (see figure 1).
  - A 1/4" NPT 1/8" hose connector is provided to connect the hose to the air filter (Part # AA111)
  - Install the air filter at a convenient point and connect to the compressed air (or gas) supply.

CAUTION: Does Not Use Oxygen, Hydrogen, or any combustible gas as a propellant, an explosion or fire could result.

C. Ground Wire Connection: An insulated wire, with #10 terminals at the ends, is supplied in order to ground unit against any static charges generated by the powder flowing through the hoses in the unit. A grounding terminal is located on the rear of the unit adjacent to the air supply hose. To connect the wire, proceed as follows:

- a. Connect the ground wire to this terminal with the hardware provided.
- b. Connect the other end of the wire to the thumbscrew that secures the lamp housing to the work chamber or to any other convenient earth/ground point.

IMPORTANT: Failure to connect the grounding wire can result in the operator being subjected to static electricity shocks when using the system.

D. Dust Collector Installation:

- a. Connect the dust collector to the work chamber with the flexible tube and metal clamps provided.

IMPORTANT: The Unit requires a dust-collecting hood placed near the unit to collect powder. Airbrasive Jet Technologies offers dust collectors and exhaust chambers.

## Section 3: Operation Instructions

### OPERATING INSTRUCTIONS

To operate the Airbrasive Unit, proceed as follows:

- A. Fill the powder supply chamber (See Section 2-3.1).
- B. Turn on the dust collector.
- C. Install nozzle onto the handpiece and place it into the work chamber.
- D. Turn the On/Off switch to "On".
- E. The indicator turns red when the powder chamber is pressurized. Look at the pressure gauge and adjust the air pressure. For most applications is 65 PSIG (4.4 bar).
- F. Adjust the "powder flow lever" to the middle of the flow range.
- G. Direct the nozzle at the workpiece and fully depress the footswitch.

IMPORTANT: THE FOOT-SWITCH MUST BE FULLY DEPRESSED FOR THE UNIT TO FUNCTION PROPERLY.

- H. Adjust the powder flow rate, operating pressure, and/or nozzle tip distance as necessary, to accomplish the desired result.

**IMPORTANT: This unit is equipped with safety interlocks. The powder section cannot be pressurized unless the door is FULLY CLOSED. Also, the door cannot be opened unless the unit is turned "OFF". DO NOT FORCE THE DOOR! This may damage the unit. If the door will not easily open with unit turned "off", consult the "Trouble Shooting" chart.**

Item	Panel Title or Name	Function or Operation
1	Air pressure gauge	Indicates operating pressure
2	Main air pressure regulator control knob	Adjusts operating pressure
3	Red indicator	Indicated pneumatic power to unit
4	Power ON/OFF switch	In ON position provides pneumatic power to unit
5	Powder flow lever	As lever is pushed to the right, powder flow increases
6	Handpiece	Holds the nozzle through which powder flows

### OPERATING PROCEDURES

- A. **GENERAL INFORMATION:** The following paragraphs describe the Airbrasive Jet Machine cutting process, the value and use of cutting speed, the selection and purpose of the amount of powder flow to be used, and the selection of air pressure.
- B. **THE AIRBRASIVE JET MACHINE CUTTING PROCESS:** The unit performs a cutting action by the impact of sharp-edged powder particles on a hard surface. Airbrasive powders are recommended. The use of other commercial powders can cause excessive maintenance repairs.

The powder stream exits the nozzle about .018" in diameter for approximately 1/16" away from the tip. Then the spray pattern spreads out in a conical shape with a total included angle of 7 degrees. To obtain sharp definition, as in precision cutting, the Nozzle Tip Distance should be kept to a minimum, approximately 1/32".
- C. **CUTTING SPEED:** Adjusting the powder flow may vary speed of cutting. Further variation may be obtained by using different pressure settings, powders, and special types of nozzles.
- D. **ADJUSTMENT OF POWDER FLOW:** When the foot switch is depressed a mixture of powder and air will be discharged from the handpiece nozzle. The POWDER FLOW lever controls this mixture.
- E. **PRESSURE BEHIND THE NOZZLE:** Pressure behind the nozzle (with powder flowing) of approximately 65 PSIG has been found to be satisfactory.

## Section 4: Service Instructions & Component Maintenance

### PERIODIC INSPECTION

This unit should be inspected periodically for the following signs of wear.

- A. Damaged case or cover
- B. Frayed or worn hoses
- C. Worn nozzle
- D. Loose hose connections
- E. Worn Pinch Tube
- F. Air Filter

### PERIODIC CLEANING

- A. Clean out dust, dirt, and spilled powder from the Unit's interior using low pressure compressed air. Remove stubborn dirt with a brush. Do not use cleaning fluid on the hoses.
- B. Clean the external surface with a soft lint-free cloth moistened with a suitable non-toxic cleaning solution.

### COMPONENTS & MAINTENANCE

- A. Nozzle and Hose Assembly: Three nozzle assemblies are supplied with the unit. Nozzle tips are made carbide and must be handled with care. Nozzle assemblies with tips for special applications are available.

- a. Nozzle Assemblies: A fuzzy powder stream, with lack of definition means that the nozzle is worn and should be replaced. To replace, simply unscrew the nozzle assembly from the connector and install a new one. Make sure nozzle assembly is tightened snugly (do not over tighten) and screw threads are not crossed.

CAUTION: Nozzles should be stored in a safe place when not in use.

- b. Nozzle Clogs: To unclog a nozzle, do the following:
      - i. Turn the unit off and relieved of air pressure and remove nozzle.
      - ii. Slide POWDER FLOW control lever completely to the left.
      - iii. Turn nozzle around hold tight up against the nozzle connector.
      - iv. Turn unit on and press foot switch to reverse flush the clogged tip.

- B. Pinch Valve Assembly: With the door open, the air pinch valve assembly is mounted at the top of the unit. Three hoses are connected to it. Two of the hoses are to the pinch valve tube. The other hose, connected to the bottom, is the plunger of the pinch valve assembly. The pinch Valve is Normally Open.

- C. Pinch Tube: Pressing the foot switch opens the air pinch valve tube. With air supply connected, the plunger is up pinching the tube. Pressing the Foot Switch de-energizes the plunger opening the airflow. If the pinch valve tube is always open, permitting powder flow through the pinch valve tube without the foot switch being actuated, proceed as follows:

- a. Remove and disassemble air pinch valve assembly. Inspect and replace worn or damaged parts.
      - b. Remove hose connections from base of air pinch valve assembly and check for air pressure from pinch valve regulator. If there is none then, adjust air pinch regulator for proper pressure. If this fails, replace air pinch valve pressure regulator.

- D. Pinch Tube Replacements: It is not necessary to remove the pinch valve assembly from the unit to replace this tube. Proceed as follows:

- a. Turn machine off.

- b. Remove top block from assembly. Pull the old tube off the fittings. Carefully insert new pinch tube into fittings and make certain to align the ends of the tube with the indentations in the bottom block and the tube seams parallel to the side of the block.
  - c. Carefully replace top block, again making certain that the tube ends align with the indentations in the top block. Secure top block in place with attaching hardware.
- E. Red Indicator: The on indicator actuates if the unit has pneumatic power. When the switch is in the ON position the actuator is red.
- F. Main Air Regulator: The main air regulator adjusts pressure of the main air supply within the unit. This regulator is not repairable at field level. Malfunction is not likely, but if rotation of its control knob does not have any effect on air pressure, the part should be replaced.
- G. Throttle Assembly: The throttle assembly meters powder particles into the main air stream and to the handpiece nozzle.
- H. Principle of Operation: When the foot switch is pressed, the pinch valve tube opens and air flows into the mixing chamber and out through the fitting on the throttle body. The pneumatic vibrator is energized; powder falls down into the air stream through the throttled orifice.

## Section 5: Removals, Replacements & Repairs

### TOOLS

The following is a list of tools you may need to do any removals, repairs, or replacements:

- A. Needle nose pliers
- B. Adjustable wrench
- C. Allen wrenches: 9/16" & 5/64"
- D. Flathead screwdriver
- E. Wrenches: 7/16", 1/2", 9/16"
- F. Philips head screwdriver.

### REMOVAL

- A. Removal Instructions: When working on the Model 6500 always use common sense and good, safe workshop practices. Care should be taken to assure that all removed hoses are marked to provide positive identification during replacement. Use the illustrations in the Appendix during maintenance.

**CAUTION: Turn off unit and disconnect air supply before working on Unit!**

### REPLACEMENT

The following Spare Parts Kits should be kept on hand, and replenished as parts are used:

Description	Part #	Qty
Pinch Tube	AR142	12
Spring for Vibrator Assembly	AM108	1
O-ring, O.D.-.285; I.D.-.145	AO103	1
O-ring, O.D.-.443; I.D.-.237	AO104	1
O-ring, O.D.-3.637; I.D.-3.359	AO106	2
Nozzle Connector	AQ123	6
Carbide Fitting for Pinch Valve	AR104X	4
Hose, Blue	AT118	25 ft.
Fitting Ass'y 10-32 to .103 Dia. tube	AQ114X	2

### GENERAL REPAIRS

The following section is for some general repairs.

- A. Common Problems
  - a. O-Rings: Replace any O-rings that are misshapen in any way.
  - b. Wave Spring: If the Wave Spring is broken in more than one place it needs to be replaced.
  - c. Powder: If there is any powder in the vibrator race it must be removed.
  - d. Powder Clogs: Do a visual check of the throttle body, and if any powder is present, blow it out.
  - e. Fittings: Fittings from the vibrator body and the throttle body can be removed and replaced.
- B. Disassembling the Powder Chamber: To get inside the throttle body do the following:
  - a. Turn the Unit "off".
  - b. Open the front panel.
  - c. Remove the black hose and label location, this is the main air supply to the powder chamber.
  - d. Remove the brown hose and label location from the Vibrator Inlet Air Supply.

- e. Unscrew the powder flow lever and remove.
- f. Disconnect the blue hose from the Throttle Body to the Pinch Valve Assembly.
- g. Remove the three nuts on the top of the Base Plate holding the Shock Mounts of the Powder Chamber Assembly. The Metal Chamber is now disengaged from the Unit.
- h. Use the 9/64" Allen wrench to remove the four screws from the Base Plate. Remove the ground wire.
- i. Remove the three metal washers connected to the black rubber Shock Mounts.
- j. Lift off the Base Plate.
- k. Remove the Adjustment Collar from the Throttle Body.
- l. Remove the wave spring from the Throttle Body.
- m. Unscrew the Brass Throttle Needle Body from the center of the Adjustment Collar.
- n. Remove the Steel Ball from the Vibrator Race.
- o. Remove the O-ring from the Powder Chamber.
- p. Lift the Powder Chamber Orifice out from the Vibrator Body.

C. Re-assembly:

- a. Unscrew the needle 1/2 turn before reassembling. Screw the Brass Throttle Needle into the Adjustment Collar.
- b. The brass section of the Throttle Needle must NEVER protrude from the Adjustment Collar. It rotates against the Throttle Body and the Base Plate (Keep it FLUSH).
- c. Insert the Wave Spring (lubricate with grease).
- d. Insert the Adjustment Collar Assembly into the Throttle Body and insert the Orifice with the O-Ring into the throttle body.
- e. Line up the holes on the powder chamber, Base Plate, and Throttle Body.
- f. Replace the four assembly screws.
- g. Replace the three washers.
- h. Reconnect the brown and black hoses.
- i. Reconnect the Powder Chamber Assembly to the door.
- j. Reconnect the blue hose to the Pinch Valve Assembly and the Throttle Body.
- k. Close the door halfway and insert the Powder Flow Lever through the front. Screw it into the Adjustment Collar.
- l. Turn Powder Control Lever to minimum position. Turn the Throttle Needle, with an Allen wrench, clockwise until it seats. Then turn it counterclockwise 15 – 30 degrees.

D. Repairing the O-Ring in Powder Chamber:

- a. Release the V-Band Clamp.
- b. Pull the Powder Chamber away from the Vibrator Body.
- c. Remove the O-Ring from the Vibrator Body and clean remove any powder from the grooves.

**IMPORTANT: Be careful not to damage the O-Ring.**

E. The Pneumatic Section: To remove the Pneumatic Section from the Unit:

- a. Open door halfway. Remove the screw located on the base of the unit perpendicular to panel face. It is directly beneath the on/off switch.
- b. Lift the panel up and toward you.

## SERVICE TIPS

- A. Flow Difficulties: Some causes of powder flow difficulties are as follows:
  - a. Worn or clogged nozzle assemblies.
  - b. Over filled or nearly empty mixing chambers. Note, also, that a slightly heavier flow may be noticeable just after the powder chamber has been filled.
  - c. Reused, contaminated, or improper powders. Use of Airbrasive powders is recommended.
  - d. Insufficient nozzle pressure, due to leaks.
- B. Testing for Leaks: Observe the following service tips:
  - a. Turn on air pressure until the system is pressurized. Shut off the external air supply valve and watch the AIR PRESSURE gauge. If the pressure drops more than 15 PSIG during the first five minutes then, the system leakage is more than one cubic foot per hour. Check fittings and components for leaks
  - b. Most leaks can be traced either by ear, touch, or use of soap and water. The presence of powder can indicate a leak.
  - c. Powder Chamber may require periodic replacement of O-Ring.
  - d. Immersed nozzle tip in water. Pressurize system with the pinch valve tube closed. Leakage through the pinch valve tube should not exceed three bubbles per second.

# Section 6: Illustrated Parts Breakdown

FRONT, SIDE & REAR VIEW

## FRONT VIEW

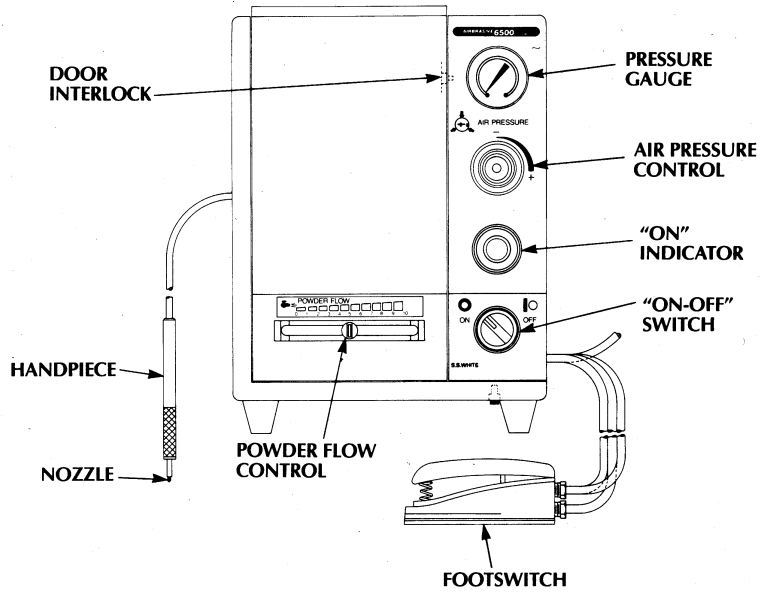

## SIDE VIEW

## REAR VIEW

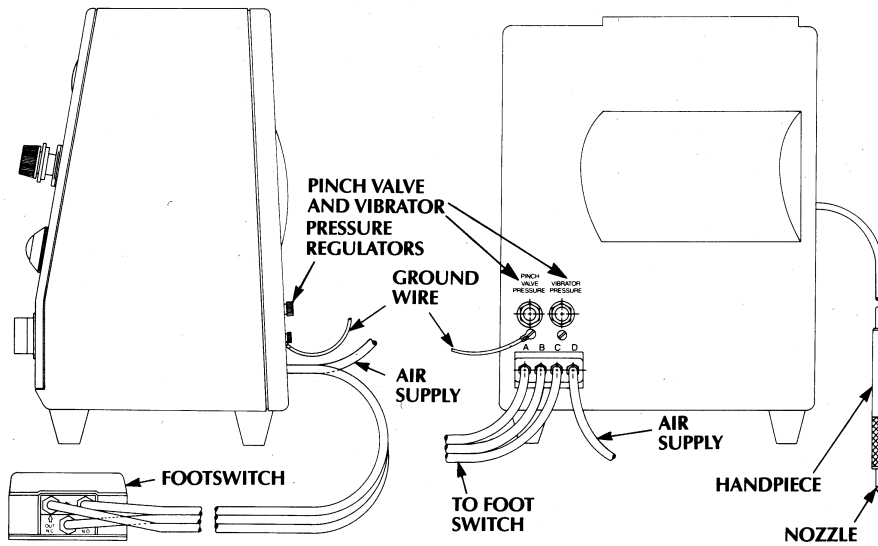

## rigui e 2 Poivder Transport System

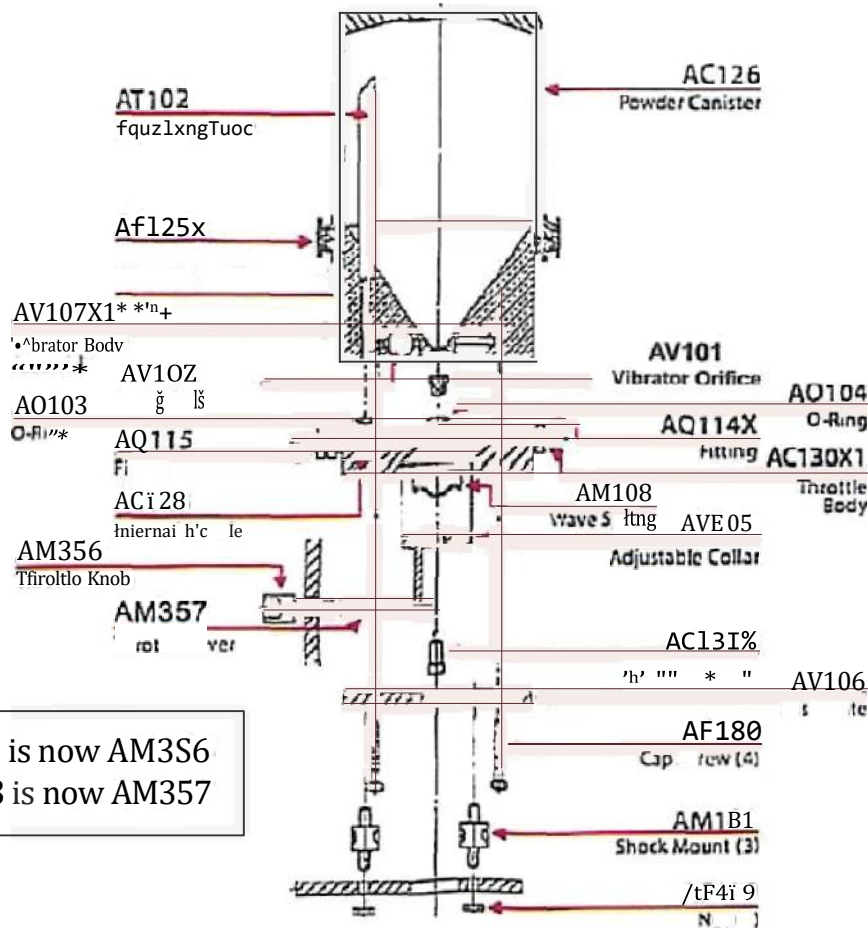

Old AM101 is now AM356  
Old AM103 is now AM357

### Disassembly / Assembly Instructions

Remove the door clamp and remove the vibrator body assembly. type clamp and remove the vibrator body assembly.

Unscrew throttle lever, remove nuts which secure shock mounts to door, remove vibrator body assembly from unit (door).

**Step 3**  
Remove 4 screws from base, unit is now ready for further disassembly in the sequence indicated in the exploded diagram at left.

Assemble in reverse order. **IMPORTANT!** Make sure before tightening screws, that the throttle needle is not in contact with the orifice. This can be accomplished by turning the setscrew located in the square hole of the throttle body.

When assembly complete adjust the throttle needle by setting the powder flow control to zero and then turning the throttle needle set screw clockwise until you feel it lightly contact the orifice. Do not tighten further.

PINCH VALVE ASSEMBLY

**AR113**

Screw, Knurled

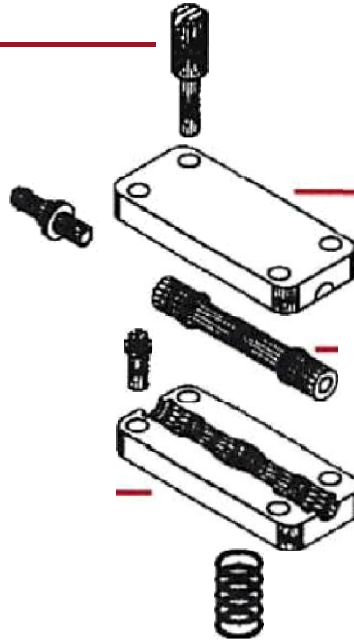

**AR119**

Block, Top

**AR142**

Tube, Pinch

**AR104X**

Fitting, Hose (2)

**AR126**

Spring

**ARJ 29**

Depressor



**AR117**

Sleeve

**AR121**

Diaphragm

**AO118**

O-Ring

**ARJ 15**

Plunger

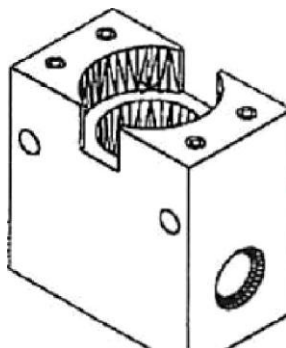

**AR171**

Body

CROSS SECTION OF MODEL 6500 FRONT PANEL

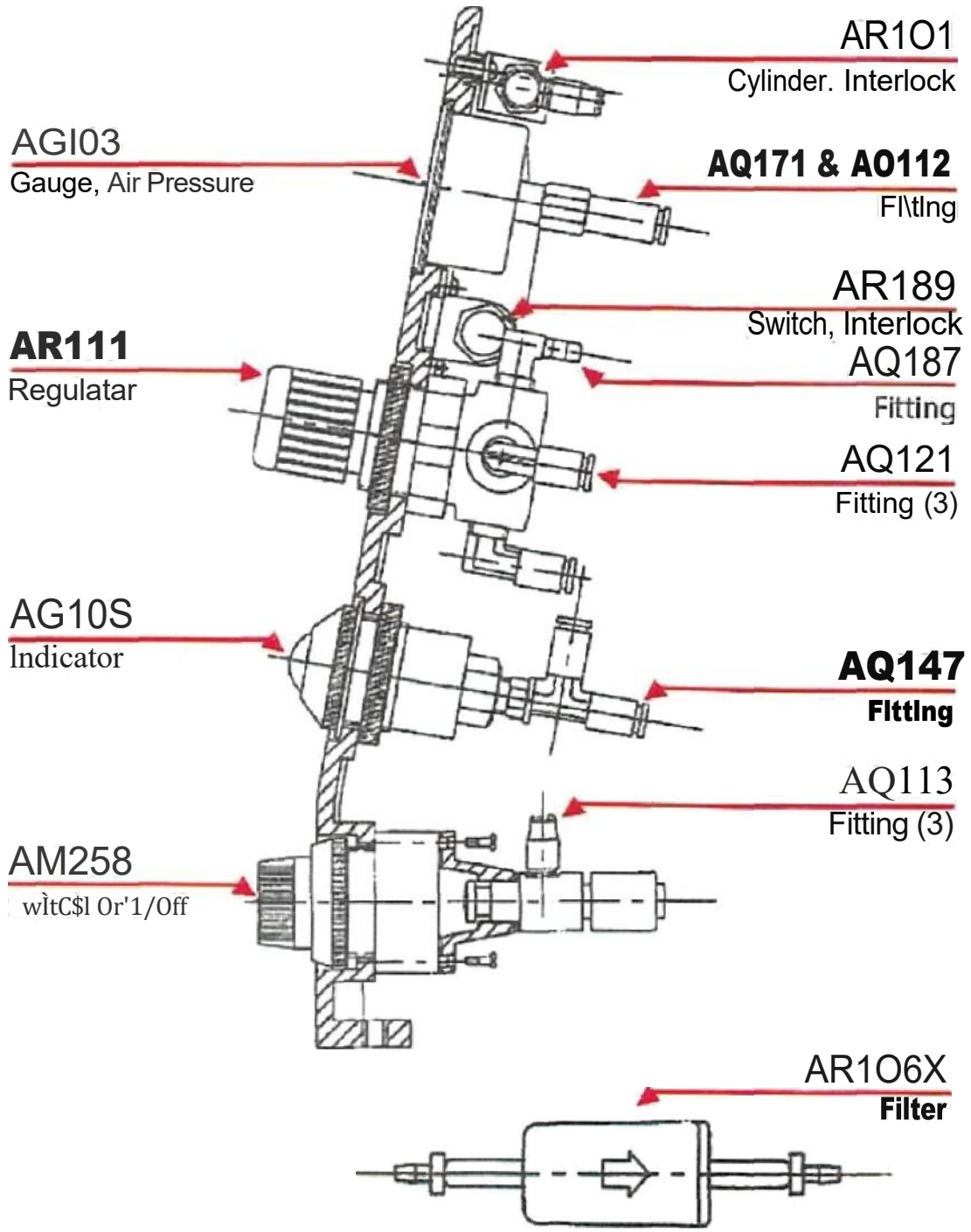

HAND PIECE ASSEMBLY (AH101X)

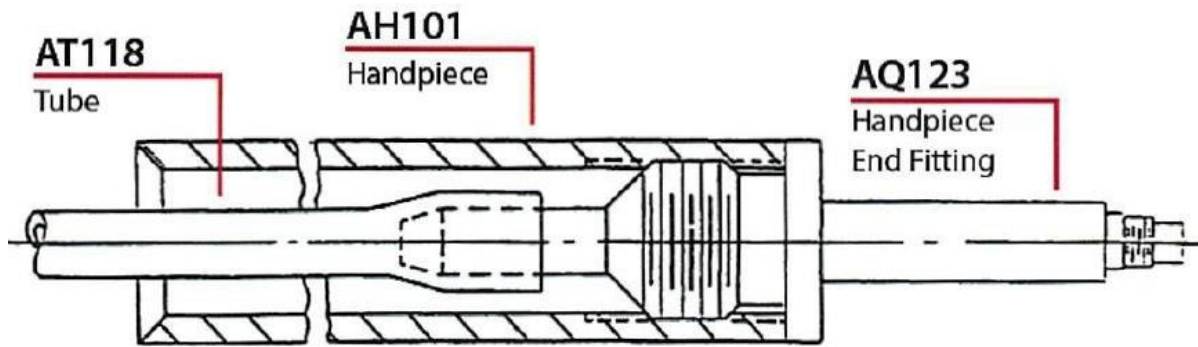

PNEUMATIC DIAGRAM

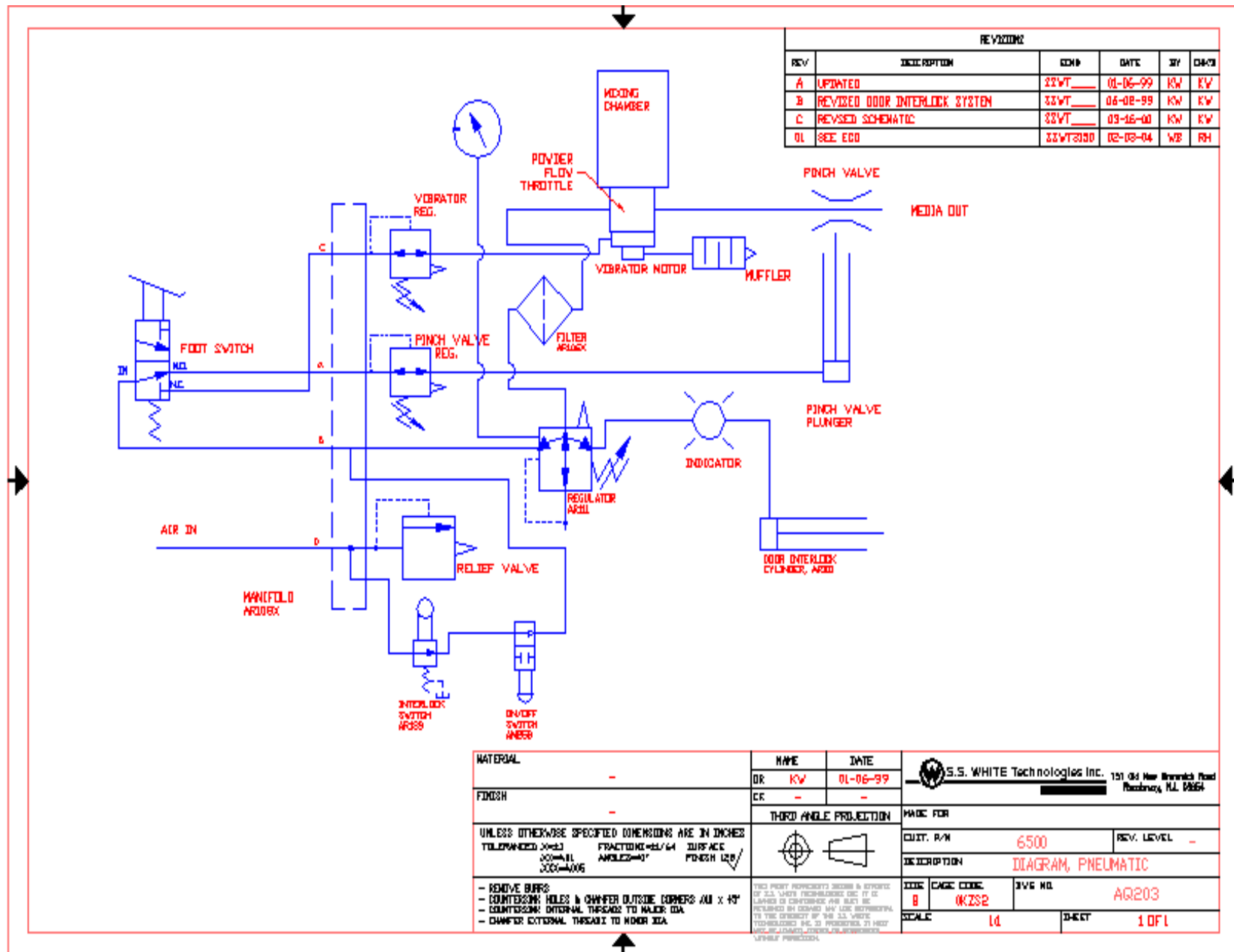

## Airbrasive Model 6500 Tech Sheet

### Model 6500

---



### Features

---

- ✓ All pneumatic operation
- ✓ Quick change powder chamber
- ✓ Most economical arrangement
- ✓ Pinch valve shutoff
- ✓ Independent air and powder flow control

### Description

---

The Model 6500 is an innovative, pneumatic micro-blasting machine. This unit was designed with portability in mind and for ease in field use. For powder flow control in the 6500, the vibration required to feed powder is generated by a novel "rotating ball" design with compressed air as its source of energy.

With an all-pneumatic vibrator mechanism, a quick powder change feature is viable. The powder compartment is comprised of a two-piece powder chamber that can be flipped and taken apart for easy filling within 30 seconds. The powder chamber capacity is roughly 2 pounds.

If you are looking for a compact, versatile, low-cost unit with a "quick powder change feature", this is the unit for you.

### Specifications

---

Pressure	Up to 140 PSIG
Min. Line Pressure	50 PSIG
Air Supply	5 SCFM (2.4 L/sec)
Chamber Capacity	2 lb. (0.9 kg) of powder
Powder Flow	Up to 40 grams/min
Relief Valve Setting	140 PSIG (9.8 kg/sq. cm)
Dimensions (in.)	13" x 9-5/8" x 7-1/2"
Dimensions (cm)	33.0 cm x 24.5 cm x 19.1 cm
Weight	18 lbs. (8.1 kg)

## Airbrasive Model 6500 Tech Sheet

### Model 6500



#### Standard Accessories (Included)

Description	Part #	Qty
Nozzle & Handpiece Assembly	AH101X	1
Foot Switch	AR105	1
Nozzle (Straight, Round, .032" I.D.)	AN106	1
Nozzle (Straight, Round, .018" I.D.)	AN119	1
Nozzle (Straight, Rect., .006" x.060")	AN124	1
AccuBrade 27 – Aluminum Oxide	AP101	4 lb.
AccuBrade 50 – Aluminum Oxide	AP105	4 lb.











#### Recommended Accessories (Not Included)

Description	Part #	Qty
Work Chamber, 110V or 220V	AA106	1
Dust Collector, 110V or 220V	AA122	1
Air / Oil Filter	AA111	1

#### Recommended Spare Parts (Not Included)

Description	Part #	Qty
Spring for Vibrator Assembly	AM108	2
O-Ring OD-3.637" ID-3.359"	AO106	2
O-Ring OD-0.285" ID-0.145"	AO103	2
O-Ring OD-0.443" ID-0.237"	AO104	2
Fitting Assembly UNF to 0.103 Dia.	AQ114X	2
Nozzle Connector	AQ123	6
Carbide Fitting Ass'y Pinch Valve	AR104X	4
Powder Filter Assembly	AR106X	1
Bottom Block, Std. Pinch Valve	AR112	1
Top Block, Standard Pinch Valve	AR119	1
Pinch Tube	AR142	10
Tubing OD-0.170 ID-0.062 Blue	AT118	25 ft.

## Nozzle Selection Guide

Nozzle Category	Type A	Type B	Type C	Type D	Type E	Type F	Type G	Type H	Type S	Type T	Adapter
Nozzle Type/Angle	Straight	Industrial	HME Only	90-degree	45-degree	Straight	90-degree	90-degree	Straight	90-degree	Industrial
Tip Material	Carbide	Carbide	Carbide	Carbide	Carbide	Carbide	Carbide	Carbide	Sapphire	Sapphire	
Orifice Shape											
Inner Dia.											
Outer Dia.											
0.005"	0.034"	AN104									
0.006"	0.020"						AN113				
0.007"	0.150"					AN102					
0.008"	0.040"	AN139				AN130	AN129	AN128			
0.008"	0.060"					AN124	AN136	AN127	AN138		
0.010"	0.030"					AN111					
0.011"	0.052"	AN126									
0.014"	0.035"	AN146									
0.018"	0.053"	AN119	AN117		AN118	AN120			AN143		
0.026"	0.075"	AN122	AN115		AN121				AN107	AN108	Model HME: AN147
0.032"	0.070"	AN106	AN116		AN109						Model K or H: AN148
0.050"	0.187"			AN145							
0.075"	0.187"			AN145T75							

Our Customer Service team is always available to ensure your complete satisfaction. Please contact us at (866) 272-0540 or at [info@airbrasive.com](mailto:info@airbrasive.com) for general inquiries or price quote requests, and one of our team members will respond within 24 hours.

## Handpiece Diagrams

### Model K

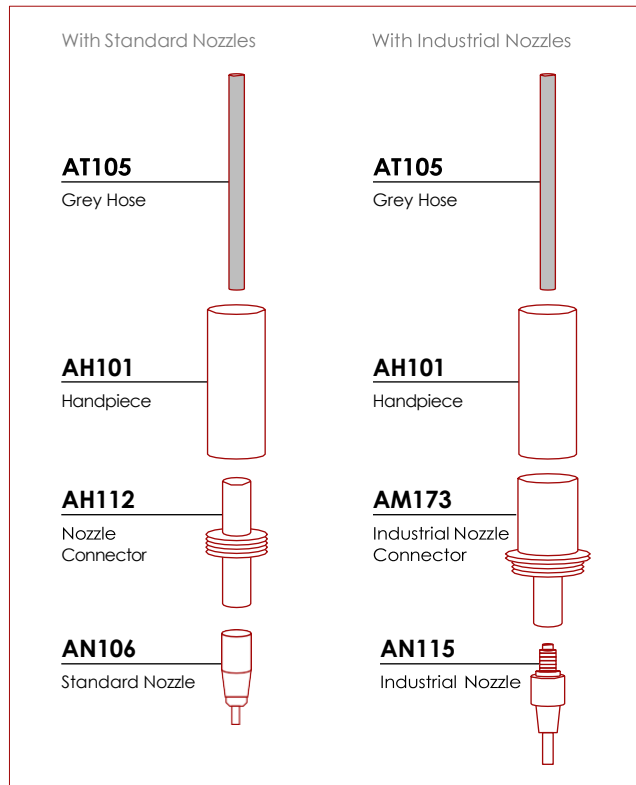

### Model H

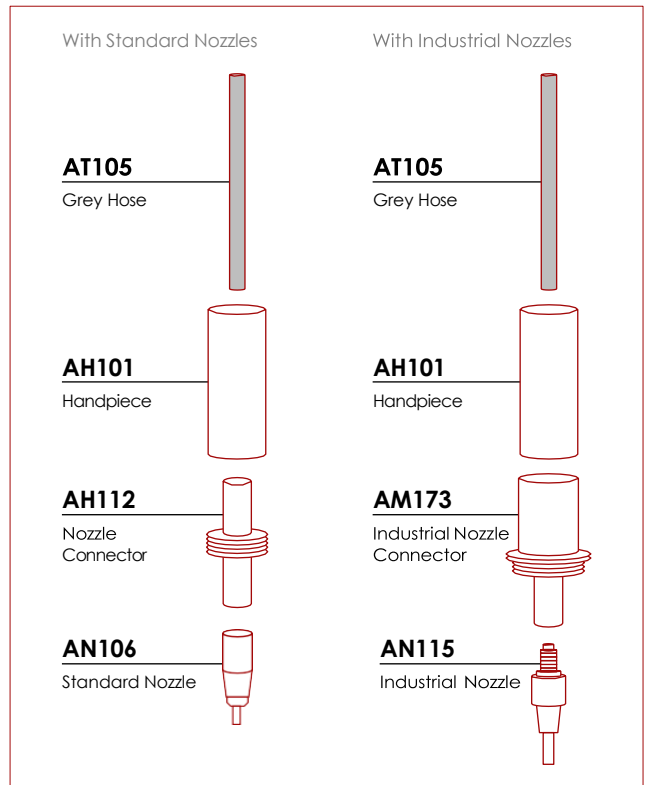

### Model HME

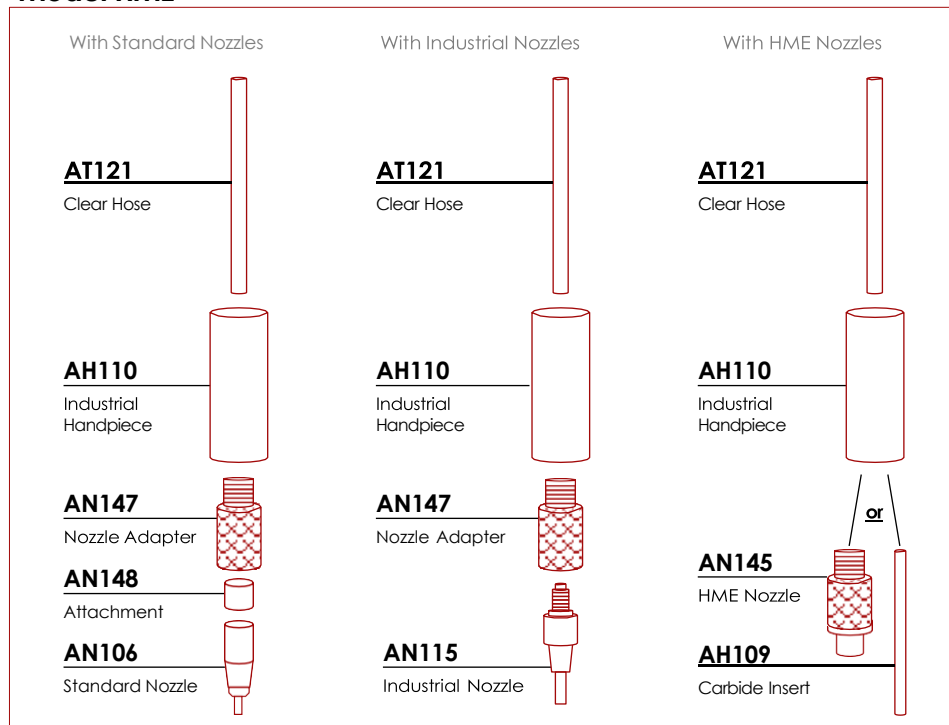

### Model 6500

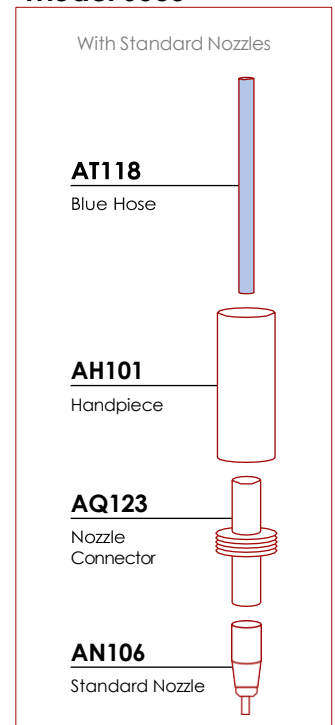

## Powder Selection Guide

Airbrasive's powders were developed specifically for use with our Micro-Abrasive Blasting Units. These powders have proven their excellent performance and reliability for many years.

Our powders are:

✓ **Triple Screened**

✓ **Sieve Tested**

✓ **Vacuum Packed**

✓ **Purity Tested**

✓ **Re-sealable**

✓ **Shipped Overnight**

Powder Type	Particle Size (μ)	Best Used For...	Very Good For...	Bottle (3-4 lb.)	Small Pail (15 lb.)	Large Pail (35-50 lb.)
Aluminum Oxide	10.0	• <b>Abrading</b>	• Aggressive Cleaning • Etching			AP108 (40 lb.)
	17.5	• <b>Abrading</b> • <b>Aggressive Cleaning</b>	• Etching			AP110 (45 lb.)
	27.0	• <b>Etching</b>	• Abrading	AP101 (4 lb.)	AP121 (15 lb.)	AP102 (50 lb.)
	50.0	• <b>Deburring</b>	• Abrading • Cutting • Drilling	AP105 (4 lb.)	AP123 (15 lb.)	AP106 (50 lb.)
Sodium Bicarbonate	50.0	• <b>Coating Removal</b>	• Delicate Cleaning			AP112 (35 lb.)
Silicon Carbide	50.0	• <b>Cutting</b> • <b>Deburring</b>	• Abrading • Drilling • Etching			AP115 (45 lb.)
Glass Bead	44.0	• <b>Peening</b>	• Delicate Cleaning			AP117 (40 lb.)
Crushed Glass	70.0	• <b>Aggressive Cleaning</b>	• Abrading			AP119 (35 lb.)

Our Customer Service team is always available to ensure your complete satisfaction. Please contact us at (866) 272-0540 or at [info@airbrasive.com](mailto:info@airbrasive.com) for general inquiries or price quote requests, and one of our team members will respond within 24 hours.